

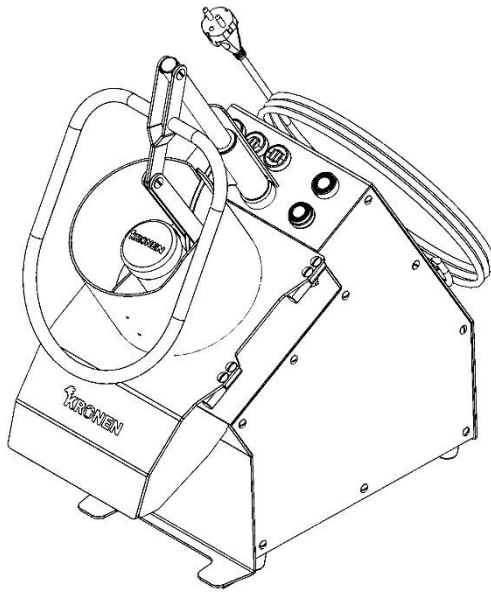

Vegetable Slicer

Type: **KG-203**



Translation of the
Original Instruction Manual



English

Contents

1. General Information	4
2. Safety.....	8
3. Technical Characteristics	10
4. Installation and Function	11
5. Transportation and Packaging	17
6. Installation and Initial Operation.....	18
7. Use and Operating.....	19
8. Malfunctions	30
9. Maintenance	32
10. Appendix.....	35
11. Index.....	37

1. General Information

Always keep the instruction manual and all the other documents near the vegetable slicer. Before using the machine the first time, make sure that you read the instruction manual first.

Explanation of the symbols used in the documents



Attention, you have to follow the instructions to avoid harm for you and the machine.



Caution, risk of injury! Follow the instruction to avoid injuries.

Limitation of liability

If you do not follow the instruction manual, the manufacturer is not liable.

Manufacturer

**Kronen Küchengeräte GmbH
Gewerbestr. 3
D-77731 Willstätt
Phone: +49 (0) 78 54/96 60-0
Fax: +49 (0) 78 54/96 60-50
info@kronen-germany.de**

Defects and Claims

1. Claims based on material defects shall be subject to a limitation period of 2 years after surrender of the merchandise. The Seller does not assume any liability for material defects in pre-owned merchandise.
2. We will, at our discretion, make new delivery for or subsequently improve any and all rendered services which are verifiably determined to be defective as a consequence of circumstances existing before the transfer of risk.
3. We reserve title to any and all parts which have been replaced.
4. In particular, no warranty will be assumed for damage or loss resulting from the following causes, but for which we are not accountable:
 - Natural wear and tear, intervention or repair work improperly performed by the Buyer or third parties, unsuitable or incorrect use, incorrect operation, installation, commissioning, incorrect or negligent handling, improper maintenance, use of unsuitable operating materials and cleaning agents, chemical, electrochemical or electrical factors, any modifications of the merchandise performed without our consent.
5. The Buyer shall allow the Seller the necessary time and opportunity to perform any subsequent improvement or substitute delivery which we regard, in our reasonable judgment, to be necessary.
6. In the event of legitimate complaints, the Seller shall bear the immediate costs of the subsequent improvement or substitute delivery. The total costs which we must bear shall be limited to the value of the order in the event that the places of delivery are outside the territory of Germany.
7. In cases in which the Buyer shares accountability for causing the defect, in particular in the event of breach of the obligation to prevent and reduce loss or damage, the Seller reserves the right to assert a corresponding damage compensation claim.
8. The Buyer shall, at his discretion, have the right to cancel the contract if and when – taking into account the statutory exceptions – a period which has been set for us for subsequent improvement or substitute delivery due to material defects has lapsed in vain.
9. The Buyer's rights arising from the liability for material defects may not be assigned without the Seller's consent.

Terms and Conditions of Warranty

1. The Seller hereby grants to the end customer a warranty for newly manufactured Kronen Küchengeräte GmbH appliances, provided that they remain in Germany. The warranty period shall be 12 months as of the delivery of the appliance to the end customer, but shall not exceed 18 months from the dispatch of the appliance from the works.

2. Kronen Küchengeräte GmbH will perform subsequent improvement or substitute delivery of the defective parts within the scope of the warranty, provided that the functional capability of the Kronen Küchengeräte GmbH appliance has been significantly impaired. Further claims within the scope of the warranty are excluded.

Following notification in due time of a warranty case, the Kronen Küchengeräte GmbH service department will decide how the defect is to be remedied and will discuss the subsequent actions with the customer, engaging an Kronen Küchengeräte GmbH authorised customer service centre if necessary. If and when the appliance must be shipped to a service centre for repair within the scope of the warranty, shipment shall be made at the customer's expense and risk.

3. Warranty claims are excluded in the following cases:

- Normal wear and tear
- Incorrect installation of the appliance
- Wilful damage or incorrect operation
- Damage caused by calcium deposits
- Damage caused by inspection or repair by persons who are not authorised by Kronen Küchengeräte GmbH

4. Kronen Küchengeräte GmbH restricts the terms and conditions of warranty for appliances which are intended for sale abroad. In such cases, Kronen Küchengeräte GmbH grants a warranty covering the original Küchengeräte GmbH spare parts. This warranty covers the functional capability of the spare parts, provided that they are installed correctly. Kronen Küchengeräte GmbH shall provide a replacement part in the event of a functional defect. No installation or personnel expenses which may be incurred will be assumed.

The warranty in this case is limited to 12 months as of the transfer of risk.

5. The warranty services described above are subject to the condition that all required maintenance and care work is carried out by a customer service authorised by Kronen Küchengeräte GmbH and that any and all care and operational instructions from Kronen Küchengeräte GmbH have been followed.

The warranty may not be transferred without the written consent of Kronen Küchengeräte GmbH.

6. Kronen Küchengeräte GmbH grants a function warranty of 6 months for each and every original Kronen Küchengeräte spare part, provided that it has been installed correctly. Kronen Küchengeräte GmbH shall provide an original part in the event of failure. No further claims, including claims for the cost of the replacement, can be acknowledged. Parts which are subject to above-average wear and tear by the operator are excluded from the above warranty cover.

Copyright Protection

It is forbidden to copy all the documents delivered with the vegetable slicer partly or completely without the permission of the manufacturer.

Disposal of the Machine

The slicer, respectively all the parts have to be disposed recycled according to the local rules and laws. It is forbidden to dispose the slicer with the household garbage.

2. Safety

General Sources of Danger



Wrongful use or limited knowledge of the safety instructions could result in accidents and injuries on hands and fingers.

That is why, we advise you to respect and follow the safety instructions.

- Make sure that unauthorized persons or untrained persons do not start and work with the slicer. Only persons under 14 years of age are permitted. For persons with limited physical or mental abilities, this is permitted under supervision.
- It is strictly prohibited to change or remove all the safety appliances on the vegetable slicer because this could result in serious danger for the user.
- While you are using the machine stay concentrated and never get distracted.
- Just slice goods which are listed in the instruction manual.
- Always keep your working environment clean and dry to make sure you don't slip and fall.
- Don't put objects on the slicer which don't belong there and don't use the machine as a storage place
- Before you clean the slicer make sure that the machine is disconnected from the power outlet.
- Turn off the slicer as soon as you hear unfamiliar noises or you have the feeling you might get injured.

Intended Use

The Vegetable Slicer is a technical tool which exclusively should be used for its' intended purpose.

Its only purpose is to slice vegetables in disks, stripes and cubes. You are also able to grate the vegetables. To achieve the results you want you have to use the intended slicing disks in the intended chutes.

Approved foods are fruits, vegetables, mushrooms, nuts, cheese and bread. You can process the food raw or cooked. Under no circumstances can the food be frozen.

Any different use of the machine is strictly forbidden.

A misuse of the machine could occur if one uses no or a wrong slicing disk. A overfilling of the slicer could also result in a misuse of the machine. It can also lead to a failure to operate the machine when the ejector is not installed. This can lead to a blockage of the vegetable cutter.

The vegetable slicer is intended for industrial use and only should be used by trained workers of the company.

Personal protective equipment is not needed for the use of the slicer. Stricter company rules still apply.

It is strictly prohibited to make any reconstructions on the vegetable slicer.

The full responsibility for the intended use and the compliance with safety instructions takes the operating company.



In case of an emergency turn off the machine by pushing the RED-button, this turns off the engine immediately.

3. Technical Characteristics

Weight: 25 kg
Dimensions (WxDxH): 249 x 507 x 646 mm

Connected load:

Input power	650 W
Line voltage	230 V ($\pm 23V$)
Mains frequency	50/60 Hz ($\pm 5\%$)
Electricity	8.1 A

Operating conditions:

Temperature	0°C till +40°C
Humidity	max. 90% (no condensation water)

Noise emission: Emission sound level LpA* 75.8 dB (A) ± 2.5 db
Vibrations: vibrations are possible but insignificant

Requirements for intended place:

- horizontal and flat
- Not slippery
- Table height between 600 and 900 mm

Performance data and - limits:

Net power	450 W
Speed	250/350/450 r.p.m
Recommended mains fuse	10 A

Non-ionizing radiation:

Non-ionizing radiation is not produced specific, but only technically limited by the electrical equipment (e.g. electric motors, power lines, or magnetic coils) delivered. In addition, the machine has no strong permanent magnets. In compliance with a safety distance (distance to source field implant) of 30 cm, the influence of active implants (e.g. pacemakers, defibrillators) can be excluded with high probability.

* EN ISO 11201: 2009 (class of accuracy 2)

4. Installation and Function

Depending on what slicing disk, the vegetable slicer processes food into disks, stripes or similar. The slicing disks are to be installed in the small and the big chute. The processed food falls out the vertical chute.

The vegetable slicer is powered by an engine that transfers its power with a v-belt to the slicer spindle.

Included in delivery

Delivery includes the fully assembled vegetable slicer consisting of body, lid, ejector and the handle for pushing the vegetable or fruit into the slicing department. Also in the box are all the documents including the instruction manual and the optional slicing disks.

Type Plate

The label is at the back of the vegetable slicer.

It includes following information:

- Manufacturer and Address
- Type
- Serial number
- Year of construction
- Nominal voltage
- Line voltage
- Mains frequency

Parts and Description

- **Body (1):** built out of stainless steel; fundamental base for the vegetable slicer.
- **Lid (2):** the removable lid makes sure that there is no unintended contact with the slicing chute.
- **Pushing handle (4):** with the pushing handle it is possible to push the food with a constant force into the big slicing chute. In the pushing handle is a smaller chute for the smaller food.
- **Collecting container (6):** the sliced products fall into the collecting container. To make the cleaning easy the collecting container is removable. You can also use the collecting container for optional cube gates.
- **Ejector (7):** the ejector is responsible for the transport of the processed food to the ejection chute.
- **Pusher (5):** the pusher is located at the smaller chute and the pushing handle. It makes it easier to get the material through the slicer.
- **Slicing disks (9):** the slicing disks are responsible for the right of the food. They come in different versions which are to be installed depending on what the result should look like
- **Cube grate (8):** the cube grate needs to be installed at the collecting container. With the adequate slicing disks the food will be processed into cubes.

Assembled Parts

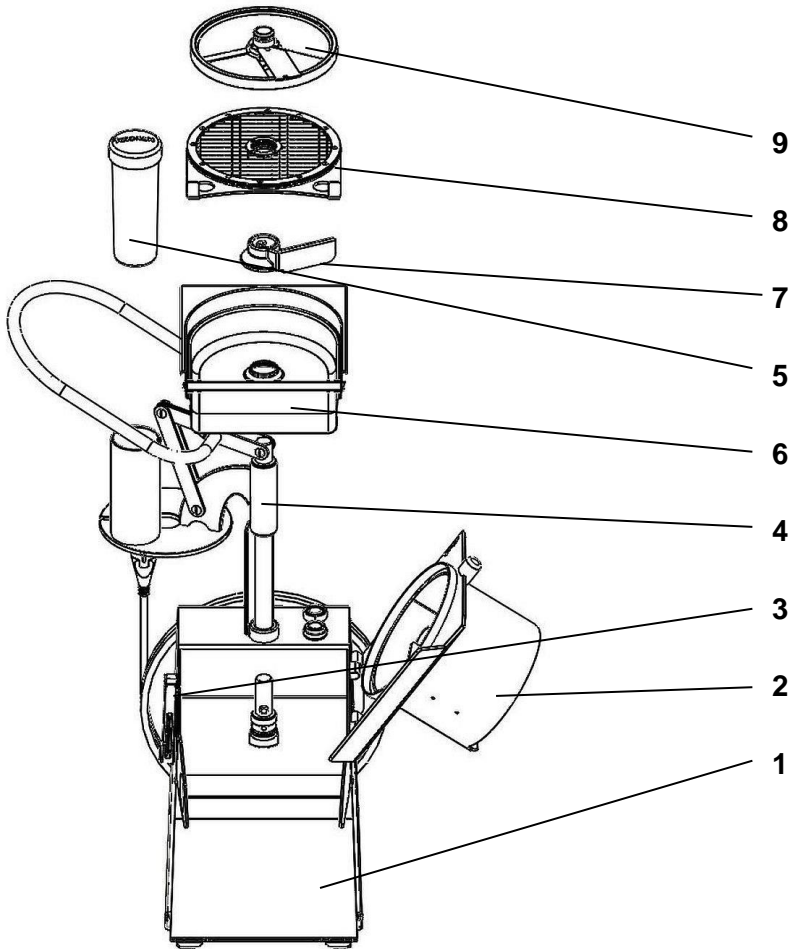

1	Body
2	Lid with big chute
3	Lid clip
4	Pushing handle with small chute
5	Pusher
6	Collecting container
7	Ejector
8	Cube grate
9	Slicing disk

Operating Elements

The vegetable slicer has five push buttons. By pushing the green button **(10)** you start the engine by pushing the red button **(11)** you stop the engine. Around the green button **(10)** is a frame to avoid an unintended turn on of the machine. On the other hand, the red button **(11)** is elevated to make a turn off easier.

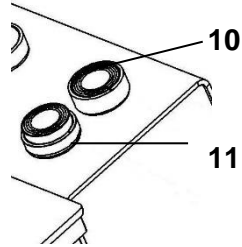

To choose between the different engine speeds you need to use the three white buttons that are marked with the numbers **I**, **II**, **III** they also represent the speed levels. Speed level **I** (button **12**) is 250 rpm, level **II** (button **13**) 350 rpm and level **III** (button **14**) is 450 rpm.

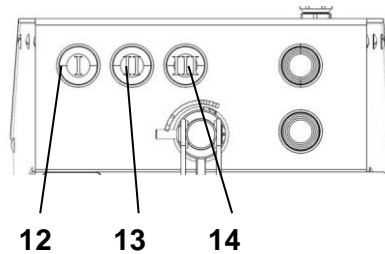

After you turn on the machine speed level **I** is in use. By pushing one of the other two buttons you can pick different speed levels. When you turn off the machine by moving the pushing handle **(4)** the speed level will not change.

When you turn off the machine by pushing the red button **(11)** or opening the lid click **(3)** the speed level resets to level **I**. the active speed level is indicated by the glowing button.



Safety Appliance

The safety appliance consists of:

- Starting the machine by pushing green button **(10)**.
- Lid clip **(3)**, you can only start the slicer if the lid is closed **(2)** and the lid clip **(3)** is clicked in. If you open the lid **(3)** the slicer automatically turns off.
- Interrupter in the body, by moving the pushing handle **(4)** to the left side you automatically turn off the engine. By moving back the pushing arm **(4)** you start the engine again.
- Engine overheating protection that turns off engine immediately if there is any possibility of overheating.
- Fusible slice- out, in case of over current to protect all the other safety appliances.

Advice: In case of loss of power or one of the safety appliances is active, not including the pushing handle, you have to start the machine again by pushing the green button.

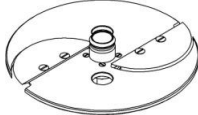
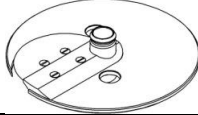
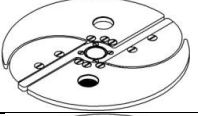
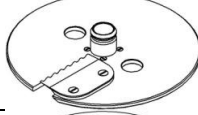
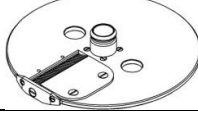
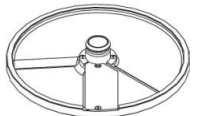
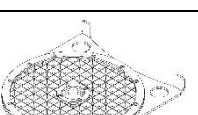
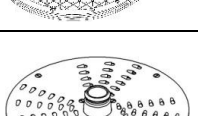
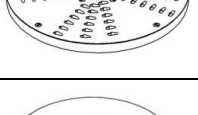
Accessories

	Slicing disk for fine-slice with 2 knives	1 mm 2 mm 3 mm
	Slicing disk for fine-slice with one knife	4 mm 6 mm 8 mm 10 mm
	Adjustable slicing disk	1 till 6 mm
	Slicing disk for raffle slice	4 mm
	Slicing disk for Julienne-slice	2.2x2.2 mm 2.5x2.5 mm 4x4 mm 6x6 mm
	Slicing disk for use with cube grate	7.5 mm 10 mm 12,5 mm 15 mm 20 mm
	Cube grate	7.5x7.5 mm 10x10 mm 12.5x12.5 mm 15x15 mm 20x20 mm
	Raffle- and grating disk	2 mm 3 mm 4 mm 6 mm 8 mm reaming disk
	Brunoise slicing disk	3 mm 5 mm
	Brunoise Head	

5. Transportation and Packaging

Always transport the slicer in the intended box.

Always transport the machine upright and make sure slicer is secured.

In case there is more than one slicer on the pallet do not put another pallet on top of it.

Check the box of possible damages when the machine is shipped.

In case of damages, talk to the responsible shipping company.

Open the box by slicing the tape with a tape slicer. Do not use sharp knives.

Lift the vegetable slicer out of the box and put it on the table.

Make sure that shipment consists out of the things you ordered. In case the shipment is not complete talk to the responsible salesman.

There are no transportation devices installed on the vegetable slicer.



Always lift and hold the machine at the body. Never lift or hold it at the lid or at the pushing handle.

Dispose or recycle the machine according to the local laws.

Store the vegetable slicer at a temperature between -10 till +40°C. The maximum humidity is 90% without condensation water.

6. Installation and Initial Operation

The vegetable slicer is shipped ready for use. This does not include the slicing disks which have to be ordered separately. The installation and the initial operation can be done by the user

The table has to fulfill certain requirements.

- Horizontal and flat
- Not slippery
- Table height between 600 and 900 mm

After you placed the slicer on the table plug in the machine in the intended outlet. The mains plug has to be viewed and easily accessible at any time by the operator.

Before you do that, make sure that the required specifications on the label are fulfilled. In case they don't match don't plug in the machine or turn it on. In this case, call the responsible customer service.

The outlet has to comply with the CEE 7/7 standards.

The electrical equipment must be protected by a faulty circuit breaker (RCD) of type A and a 10 amp fuse. In normal operation of the vegetable slicer a leakage current higher 3.5 mA may be occurring.

Before the first use make sure you cleaned the slicer. Follow the instructions in chapter "7 Use and Operating" passage cleaning.

Check the following points with slicing disks not installed.

- Check if the engine turns off when you move the pushing handle to the left side and if the engine turns back on when you move the pushing handle back to the right.
- Check if you can turn on the machine when the lid is open and the pushing handle is on the left side. This should not be possible.

In case the machine is not working properly it needs to get fixed by your customer service.

7. Use and Operating

Safety instruction for operating the slicer



It is strictly prohibited to put your fingers in the ejector while the machine is running. The risk of injury is too high.



The slicing disks have sharp knives. Be careful when touching the slicing disks to avoid injuries.



The use of the ejector is absolutely necessary. When not in use it can lead to jamming of the machine. When not in use, it can also lead to injury from the rotating shaft.

Description of danger symbols

A general danger symbol, a non-compliance with the safety regulations means danger.



Prohibition sign "**Do not grab inside**" (pictogram P015 according to EN ISO 7010)

The sign forbids access to the ejector during operation.

“To-do-list” before operating the machine

Make sure the slicer is clean especially in those areas that come in contact with the food. For example: the inside of the lid, the collecting container **(6)** and the pushing handle **(4)**. In case it is necessary clean those areas according to the instructions given in paragraph cleaning.

The collecting container **(6)** and the ejector **(7)** have to be installed on the vegetable slicer to function properly.

Turning on

To turn on the machine the slicer has to be plugged in and the lid has to be closed with the lid clip **(3)** clicked in. By pushing the green button **(10)** you turn on the machine. The green button glows to indicate the user that the machine is ready to operate. When you move the pushing handle **(4)** to right into the slicing chute or it is already in position the machine will start.

Turning off

To turn off the slicer you have to push the red button **(11)**. By moving the pushing handle **(4)** to the left or opening the lid **(2)**, the machine automatically turns off. When you close the lid or move the pushing handle to the right the machine starts again.

Speed Levels

- Level I: Choose level I (button **12**), if you process soft and sensitive material, for example tomato, salad and mushrooms. Also use this level if you need cubes.
- Level II: Choose level II (button **13**), if you want to grate or grind your material, for example carrots or cheese.
- Level III: Choose level III (button **14**), if you process hard food, for example carrots or cabbage.

Emergency Turn Off

In case of emergency, you have to push the red button **(11)** to turn off the engine.

Installing and Removing the Slicing Disks

To install the slicing disks (9) you have to move the pushing handle (4) to the left. Swing the lid clip (3) to the back and open the lid (2). Install the slicing disk (9) on the axle. Move the disk counter clockwise until the disk moves downward.

Advice: you should not be able to lift the slicing disk after your installation.

To remove the slicing disk open the lid (8) and turn the disk (9) clockwise till the end. Now remove the disk from the axle.

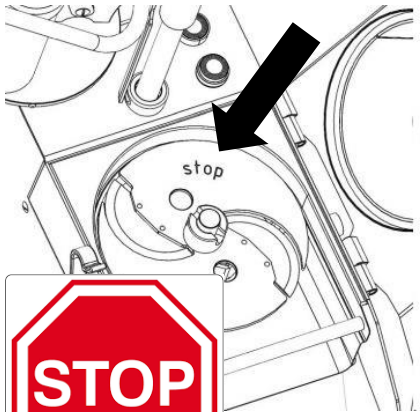
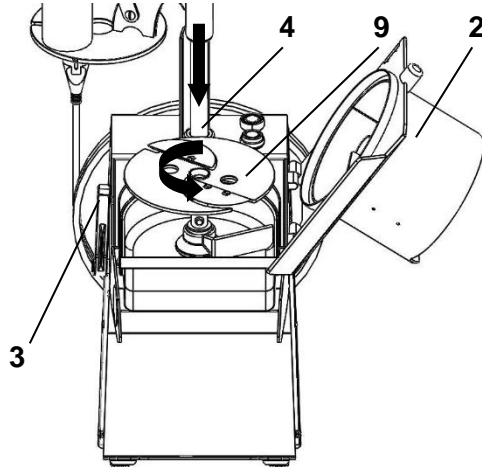

Wrong

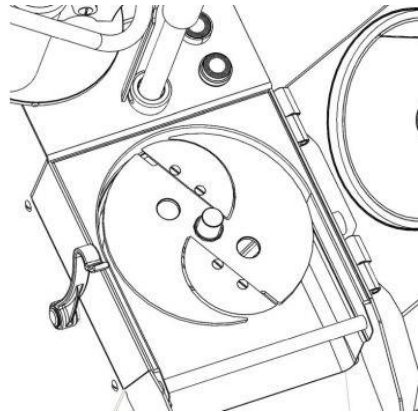

Right installation



Never start the machine if you insert the slicing disc the wrong way round. In this case you read the message STOP on the slicing disc.

Using the cube grates

When using cube grates, you have to move the pushing handle **(4)** to the left. Swing the lid clip **(3)** to the back and open the lid **(2)**.

First, install the cube gate **(8)**. Then install the slicing disk **(9)** on the axle. Move the disk counter clockwise until the disk moves downward.

Advice: When turning the slicing disc, check that it doesn't grind on the cube grate.

To remove the slicing disk open the lid **(8)** and turn the disk **(9)** clockwise till the end. Now remove the disk from the axle.

Then remove the cube grate **(8)** from the collecting container **(6)**.

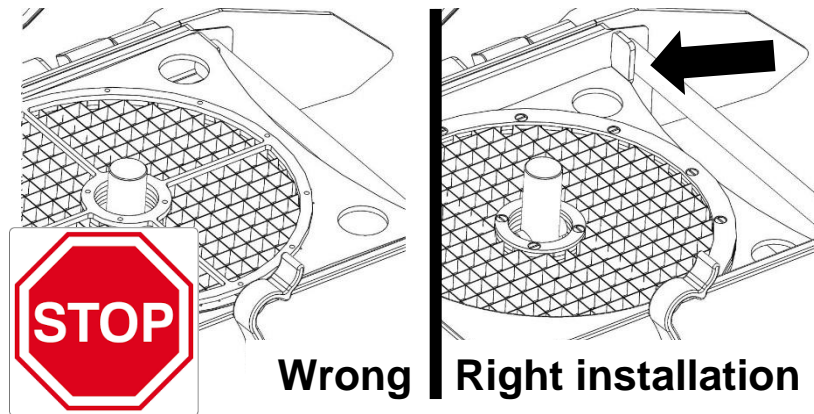
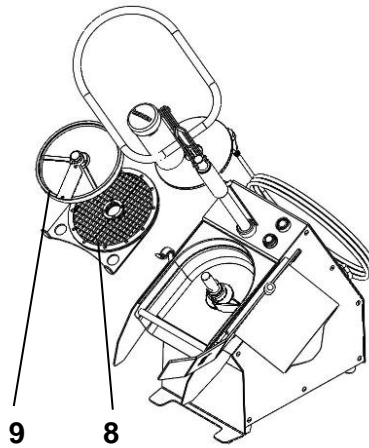

Check whether you inserted the cube grate correctly. Incorrect assembly may cause damage to the vegetable slicer.

Working with the Big Chute

The intended use of the big chute is to slice bigger chunks e.g. $\frac{1}{2}$ cabbage or a big amount of smaller pieces like mushrooms.

Before you start, make sure that the collecting container **(6)** and the ejector **(7)** are installed. Install the slicing disk and close the lid.

Advice: before operating the slicer, make sure that the collecting container, axle, slicing disks, ejector as well as the chute and the cube grate are clean.

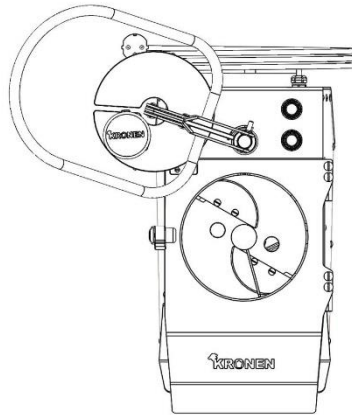

Now, you can place the food in the chute but make sure that nothing comes out of the chute because you won't be able to move the pushing handle **(4)** over the chute. Turn on the machine by pushing the green button **(10)**. Move the pushing handle **(4)** to the right and move the pushing handle with little force downward.



Do not use too much force when pushing the food with the pushing handle. The vegetable slicer won't work faster. You just squeeze the food.

Working with the Small Chute

The small chute is located at the pushing handle **(4)**. Its purpose is to slice long and thin material (e.g. cucumbers or carrots).

Before operating make sure that the collecting container **(6)** and the ejector **(7)** are installed. Install the slicing disk and close the lid. Move the pushing handle **(4)** to the right and slide it to its lowest position. Remove the pusher **(5)** out of the small slicing compartment and fill the small compartment with material. Start the engine by pushing the green button **(10)** and use the pusher **(5)** to push the food with moderate force.

Advice: Insert the long material always with the peak first.

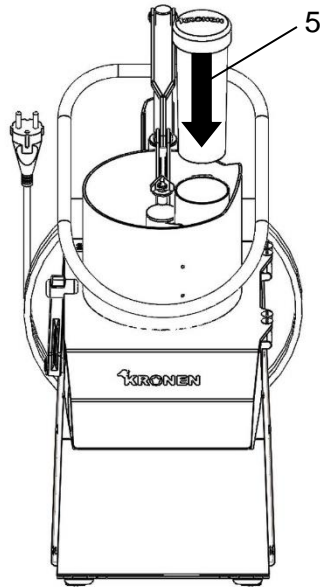

Never use anything else but the pusher (5) for pushing down the material.

Removal of the pushing handle and the lid

For cleaning you can remove the pushing handle (4) and the lid (2). To do this push the pushing handle (4) into its upper position and turn it this left. Now you can lift the pushing handle (4) upward from its opening. To remove the lid (2) release the lid clip (3) and open the lid (2) by turning to the right, now you can pull the lid (2) from the machine body (1).

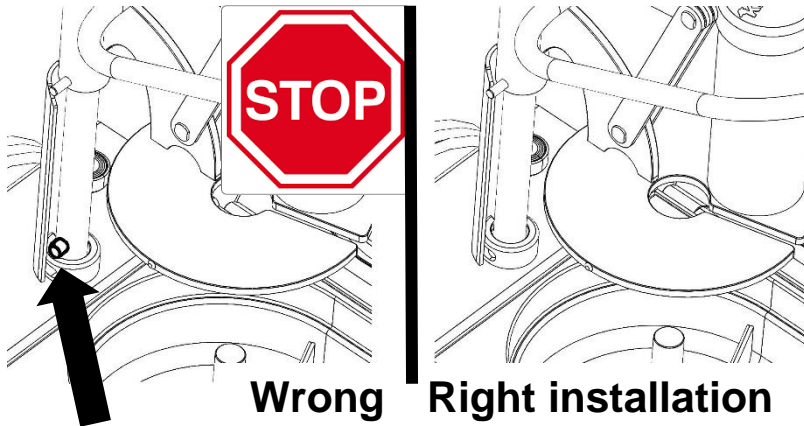
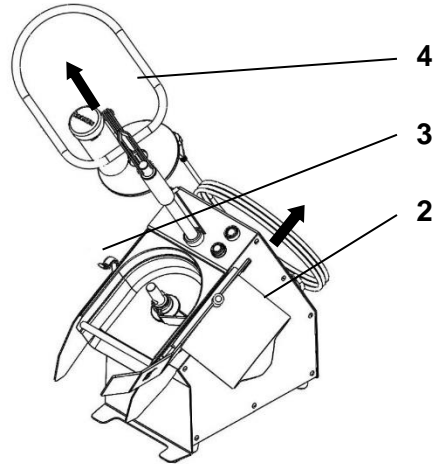

When installing the pushing handle, make sure that the bolt on the rod snaps into the groove. If installed incorrectly, you cannot switch the machine on.

Installing the Brunoise Head

To work with the Brunoise Head (17), the pushing handle (4) and the lid (2) have to be removed.

For insertion, push the hinge joint from the Brunoise Head to the hinges on the machine body (1). Now you can close the Brunoise Head (17) and insert the rod (18) in the opening of the pushing device (4). Then lock the Brunoise head with the lid clip (3).

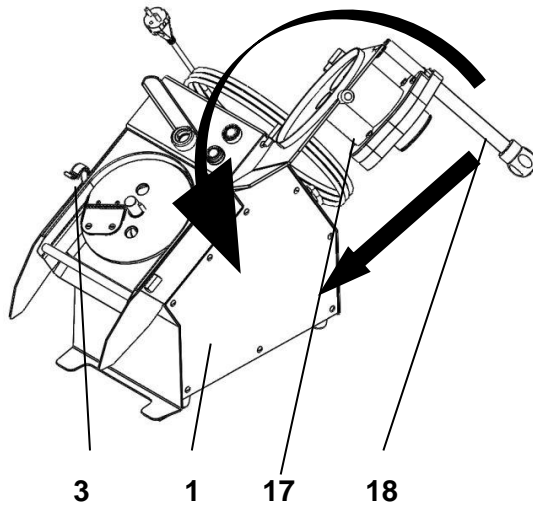

Working with the Brunoise Head

This is used to processed vegetables (e.g. courgette, carrots, kohlrabi, and celeriac) into small cubes.

Make sure yourself before starting the work that the collecting container (6) and the ejector (7) are mounted. Insert the appropriate Brunoise slicing disk, close, and lock the Brunoise Head (17). Turn the handle of the rod (18) at the Brunoise Head counter-clockwise until it stops. Then insert the filling tube (20).

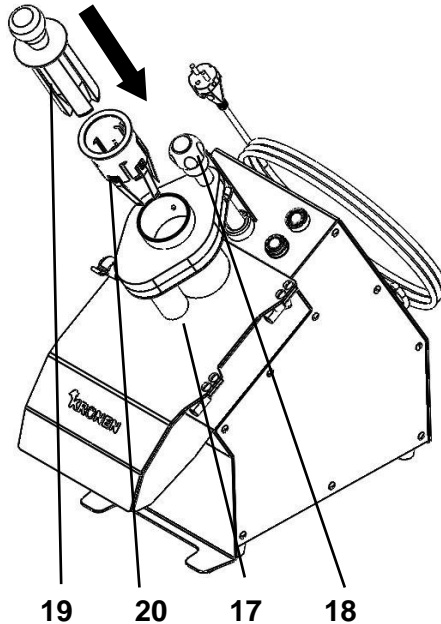

Note: You can only open the Brunoise Head, when you completely pull out the rod (18) from the pushing device opening.

Remove the pusher (19) from the filling tube (20). You can now insert the cutting material into the hole. Springs in the filling tube prevent the cutting material from falling onto the slicing disc and cutting it too early. Turn on the vegetable slicer with pressing the green push button (10). With the pusher (19) press the cutting material down. To refill, you do not have to switch off the vegetable slicer. You can refill cutting material during operation.



Only fill the feed tube with Cutting Material, that the pusher is guided in the feed tube.

Cleaning

Before you use the vegetable slicer the first time, make sure you clean it thoroughly. Also, clean the machine multiple times during the day after use.

Always use standard cleansers for cleaning the slicer.



The vegetable slicer is only protected against splash water. Do not use high-pressure cleaner, steam cleaner or similar methods.

Before cleaning, pull the vegetable slicer power plug from the socket.

After use or before using different material remove the dirt with a sponge and clean the machine with warm water and disinfectants.

Advice: The collecting container (6) is removable and made out of stainless steel which makes it no problem to put it in the dish washer.

At least once a day you should disassemble the slicer for thorough cleaning. To do that, you need to disassemble the machine in following parts: body (1), pushing handle (4), lid (2), collecting container (6), pusher (5) and ejector (7)

Clean the pushing handle (4), lid (2) and collecting container (6) in the dish washer. The body (1), pusher (5) and ejector (7) should be cleaned with warm water and disinfectants.

Reassemble the slicer after cleaning.

After cleaning, disinfect the slicing disks and rinse them with water.

Advice: For cleaning the cube grate (8) use a carrot to remove easily the remains.

Advice: Do not use any hard items to clean the slicer.

8. Malfunctions

Safety instructions



In case of unfamiliar noises or decreasing power turn of the machine immediately.



In case of blockage turn of the vegetable slicer and unplug the slicer from the outlet. After doing this you can try to remove the blocking material.



In case the slicing disk is blocked you should try to move those clockwise to release the blockage. Attention! The slicing disks are sharp.

Only customer service should disassemble parts in case of malfunctions.
In case of reoccurring malfunctions call your customer service.

Error Correction

Error	Possible cause	Solution
Machine does not start. The green button doesn't glow.	<ul style="list-style-type: none"> – Machine is not plugged in – Lid is not closed properly – Damaged fuse – Safety switch at the lid is defect – Control board is defect 	<ul style="list-style-type: none"> – Plug in the machine – Close the lid – Those malfunctions are to be fixed by customer service only.
Machine doesn't start but green light is glowing.	<ul style="list-style-type: none"> – Pushing handle safety switch is defect – Overheating protection is active – Engine is defect – Control board is defect 	<ul style="list-style-type: none"> – Those malfunctions are to be fixed by customer service only.
The cut is not satisfying.	<ul style="list-style-type: none"> – Check the slicing disk and knives. 	<ul style="list-style-type: none"> – Those malfunctions are to be fixed by customer service only.
Machine stops during operation.	<ul style="list-style-type: none"> – Chute to full – Operating capacitor is defect 	<ul style="list-style-type: none"> – Try again with less material – Those malfunctions are to be fixed by customer service only.
The processed food is not coming out of the ejector.	<ul style="list-style-type: none"> – The ejector is missing 	<ul style="list-style-type: none"> – Assemble the ejector

9. Maintenance

Safety Instructions



Maintenance, if not specifically mentioned, is not to be done by the user. Maintenance is done by customer service only.

Maintenance Schedule

Once a week, the user needs to check all safety devices.

Once a year, your customer service needs to check the tension of the v-belt and if necessary needs to readjust or exchange the v-belt.

Abrasion

Engine and gearbox bearing are lubricated for their whole lifetime. In case the bearing is defect, customer service has to exchange them.

The knives of the slicing disks have a natural abrasion. In case they become dull you can sharpen the knives again. If a sharpening is not possible anymore you need to change the disks.

You cannot sharpen the reaming- and raffle disk. You need to change the disks in case of significant abrasion.

Maintenance on the slicing disks is to be done by customer service only.

The v-belt has a natural abrasion. In case of a significant abrasion the v-belt needs to be replaced by a new one.

Checking the Safety Devices

The flawless function of the safety devices needs to be checked once a week by the user. The engine has to stop in following cases after a maximum of 2 seconds:

- When opening the lid, the engine should not start if the lid is not properly closed.
- When moving the pushing handle, distance X 45 mm of the edge of the chute.

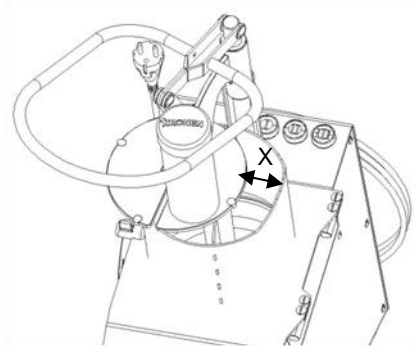

In case one of those two safety devices are defect:

- You cannot operate the vegetable slicer.
- Has to get repaired by your customer service.

Advice for vital function devices

The replacement of vital function devices is only be made by your customer service.

These include:

- circuit board art.no: 45410
- switch to lock the lid art.no: 100831
- switch to lock the pushing handle art.no: 100554
- pusher art.no: 100449

The pusher must always be stored together with the vegetable slicer. In case of loss it has to be replaced by an original spare part.

Support / Customer Service / Hotline

Sales Department and customer service:

Kronen Küchengeräte GmbH
Gewerbestr. 3
D-77731 Willstätt
Phone: +49 (0) 78 54/96 60-0
Fax: +49 (0) 78 54/96 60-50
info@kronen-germany.de

Local Sales Department and customer service:

Partner	
Street	
Zip Code & Place	
Tel.	
Fax.	
Service yes / no	

To be filled out by local representative.

10. Appendix

Declaration of Conformity

EG-machine guideline **2006/42/EG** and **EMC guideline 2014/307EU**.

Authorized Person: Christian Höltge
KRONEN Küchengeräte GmbH
Gewerbestraße 3
D-77731 Willstätt

Manufacturer : KRONEN Küchengeräte GmbH
Gewerbestraße 3
D-77731 Willstätt

declares that the following product:

Product name: Vegetable Slicer **KG-203**

Serial Number: _____

conform with the guideline mentioned on top - including the changes of the statement at this point of time.

Following engineer standards apply:

- **EN 1678** vegetable cutting machines, safety- and hygiene standards
- **EN 60204-1** electrical equipment of machines part 1 : General Operation
- **1935/2004** ordinance for materials and parts that get in contact with food
- **EN 55014-1** Electromagnetic compatibility - Part 1 Emission
- **EN 55014-2** Electromagnetic compatibility - Part 2 Immunity

Willstätt, the 11.07.2011

Place, Date



Frank Förster
CEO

Circuit plan

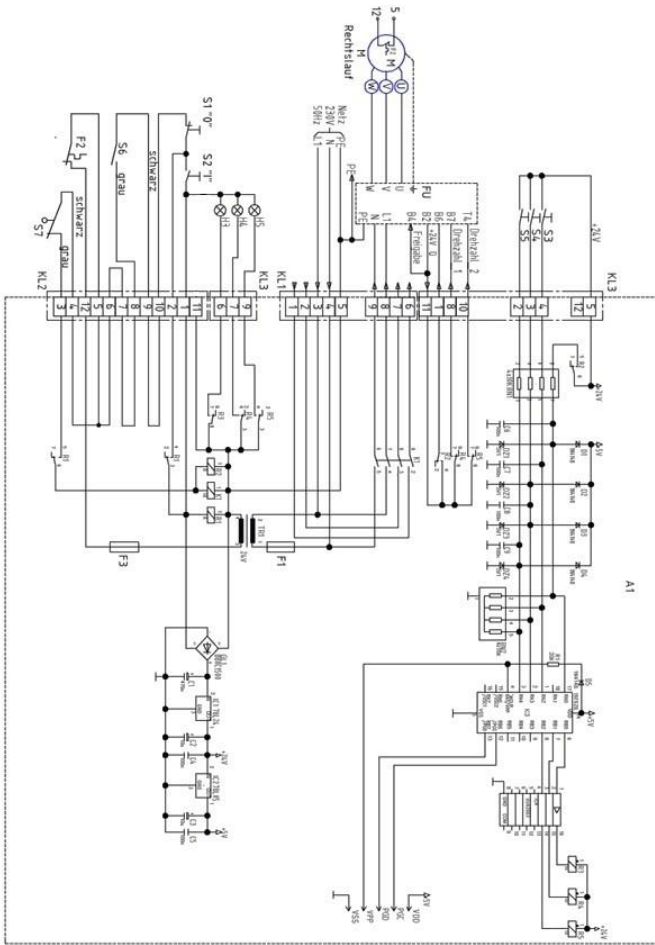

F3	safety fuse
FU	frequency converter
F1	safety fuse
H5	control light pushbutton S5
H4	control light pushbutton S4
H3	control light pushbutton S3
S7	safety switch pushing handle
S6	safety switch lid
S5	pushbutton level 3
S4	pushbutton level 2
S3	pushbutton level 1
S2	pushbutton ON "r"
S1	pushbutton OFF "0"
R2	relais release frequency converter
R1	relais
K1	motor contactor
F2	motor protection
M1	motor 3~, 230 V 50Hz, P=4,50W
TR1	transformator
A1	circuif board
	Description

11. Index

Accessories	17
Brunoise Head.....	26, 27
Circuit plan	35
Cleaning	28
Connected load	10
Cube grate.....	13
Customer service	33
Declaration of Conformity	34
Defects and Claims	5
Disposal.....	7
Ejector	13
Emergency Turn Off	22
Error Correction.....	30
Installation	12
Intended place.....	10, 19
Maintenance Schedule	31
Malfunctions	29
Manufacturer	4
Operating elements	15
Packaging.....	18
Pusher.....	13, 14, 25
Safety devices	32
Slicing disks.....	13, 14, 23
Speed Levels.....	22
Terms and Conditions of Warranty	6
Transportation	18
Turning off	22
Turning on	22
Type plate.....	12